



ZoneZ Dimmer Manual

Table Of Contents

Preparation	2
ZNZ-ZD Overview..	3
Installation Notes	4
Retrofitting an Existing System	5
Line Voltage Wiring and Connections	6
Contact Closure Switch Wiring and Connections (Dimmers 1-6)..	7
Contact Closure Switch Wiring and Connections (Scenes).....	8
Contact Closure Switch Wiring and Connections (LED)	9
Programming Interface Explanations	10
Programming Scene Functions	11
Programming LED Functions	12
Address Dip Switches	13
Option Dip Switches.....	14
Termination Dip Switches.	14
LED Intensity Dip Switches.....	14
Troubleshooting Guide	15
Frequently Asked Questions.....	16

Preparation

Unpack the ZNZ-ZD and inspect the contents for damaged or missing parts. If any problems arise, please contact Touch-Plate at 260.426.1565 for assistance.

Precautions

The ZNZ-ZD hardware is designed to be in environments that have a temperature range of 0-60°C (non-condensing atmosphere). Installing in an environment outside of these parameters will shorten the life span of the hardware.

Touch-Plate recommends the use of 18 to 22 AWG wire for low voltage wiring of contact closure products and 18 AWG wire for all 24V power connections.

All 120VAC wiring must use wire as specified by National Electric Code for load size and wire length.

Compatible Hardware

The ZNZ-ZD product can be a part of a networked, intelligent system with a Time-Keeper. It can also be a standalone item that can incorporate the following products:

Contact Closure Switches:

- 5000 Series
- Genesis Series
- Classic Series
- Eclipse Series
- Industrial Series
- Mystique Series
- Royal Series
- Ultra Series

Warranty

Touch-Plate warrants this product against defects in materials or workmanship, under normal use, for a period of ONE (1) year from date of shipment. If a defect arises and a valid claim is received within the Warranty Period, Touch-Plate will repair or replace the product at no charge.

This warranty does not apply to:

- a. Damage to unit(s) caused by accident, acts of God, inappropriate installation, faulty installation, or any negligent use;
- b. Unit(s) which have been subject to being taken apart or otherwise modified;
- c. Unit not used in accordance with instructions;
- d. The finish on any portion of the product, such as surface and/or weathering, as this is considered normal wear and tear;
- e. Non-Touch-Plate hardware installed by the user;
- f. Damage caused by Non-Touch-Plate products;
- g. Damage caused by operating the product outside the permitted or intended uses described by Touch-Plate;
- h. -or- Specific plans or Specific application requirements, unless the plans and specifications have been forwarded to Touch-Plate and Touch-Plate has approved and accepted the plans in writing.

Except as provided in this warranty, Touch-Plate is not responsible for direct, special, incidental, or consequential damages resulting from any breach of warranty or condition, including but not limited to, Installation or Replacement labor costs.



ZNZ-ZD Overview

The ZNZ-ZD is the effortless lighting solution that allows for simple dimming control.

The ZNZ-ZD has the following options:

- A RS485 Connection to Time-Keeper Master Controller
- B Termination DIP Switches
- C LED Outputs
- D Contact Closure Switch Inputs
- E Scene Inputs
- F Option DIP Switches
- G Address DIP Switches
- H Pilot Intensity DIP Switches
- I Programming Interface

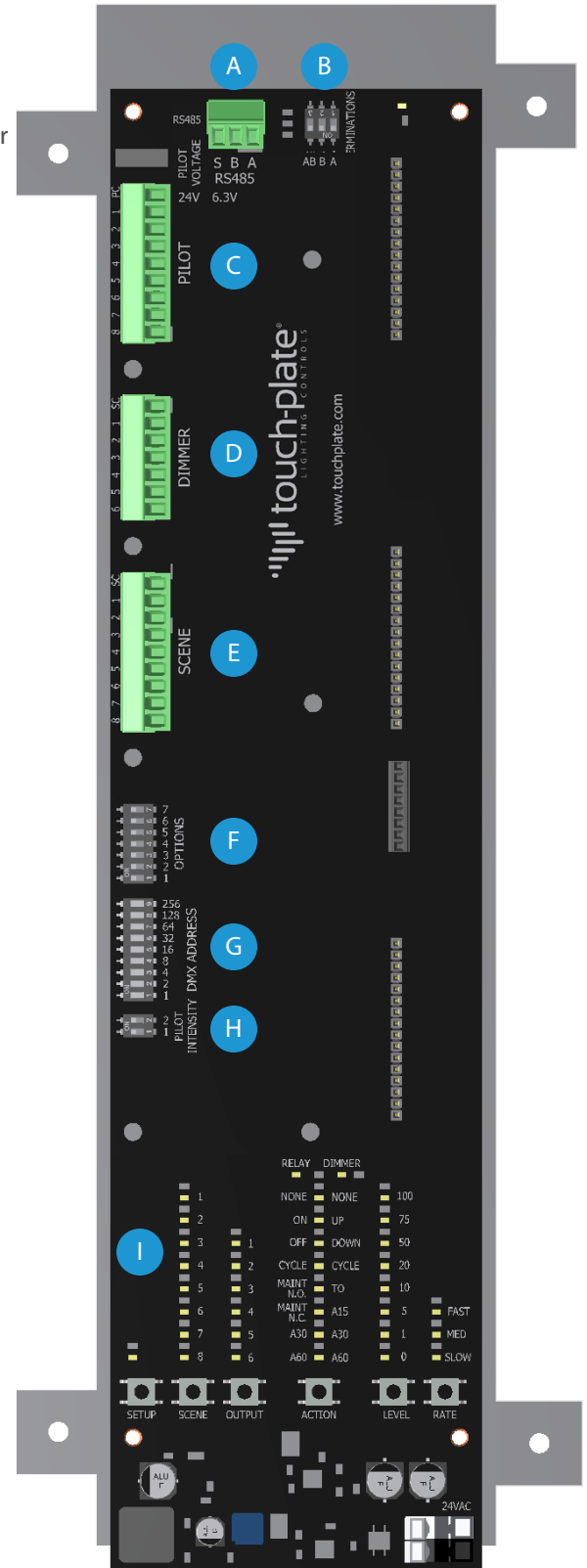

Installation Notes

The ZNZ-ZD has dimmer modules which can be removed from the system if they ever need to be replaced.

Use the following diagram and instructions on how to remove the modules from the ZNZ-ZD system.

- A** Unplug the ribbon cable from the ZNZ-ZD.
- B** Disconnect the wires from the line voltage board.
- C** Unscrew the locknut from the dimmer modules.

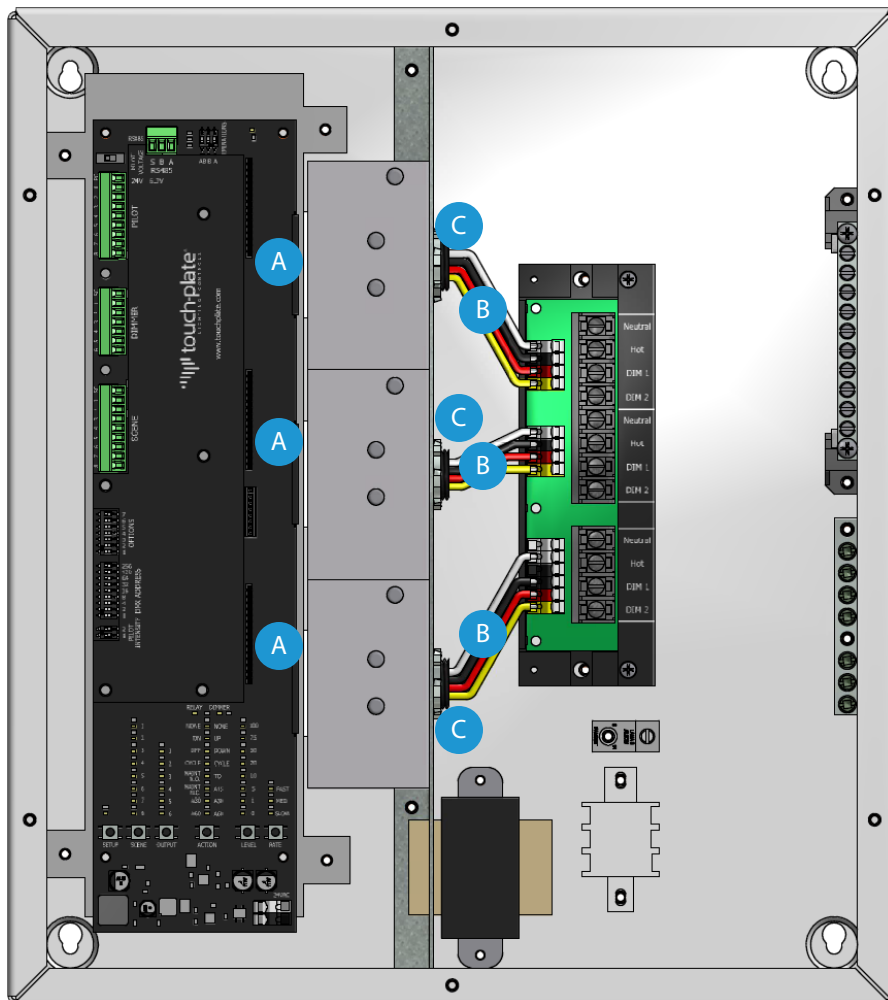

Retrofitting an Existing System

To correctly update an existing system, be sure that the entire system is being updated. Power from the circuit breaker **MUST** be turned off before removing any existing parts. Most systems that have control stations with pilot lights must have those existing control stations replaced before bringing power to the updated system.

Use the following instructions to correctly label and remove the existing system.

- A** Label all wires before or during removal. Use the following chart to identify the wires that need labeled.

Wires to be Labeled	Wire Description
Low Voltage Switch Leg	Low Voltage Switch Leg from the Switch to the Relay
Common	Common from the Switch to the Transverter (TPS/TVR)
Common	Common from the Switch to the Transformer (PL-6)
Line Voltage Switch Leg	Wire from the Breaker to the Transverter (TPS/TVR)
Breaker	Wire from the Breaker to the Lighting Load

- B** Disconnect the Transverter (typically a TVR-1 or TPS-0120).
- C** Disconnect the line voltage from the relay (two wires from the base of the relay); many times the Hot wires are jumped together.
- D** Disconnect the low voltage from the relay (wires from the coil of the relay).
- E** Disconnect the pilot light transformer from the lighting load and control station(s). The line voltage wires connected to the pilot light transformer are no longer needed.
- F** Remove the enclosure with all the relays, transverter, and pilot light transformers disconnected. If reusing the enclosure, only remove the relays, transverter, and pilot light transformers.

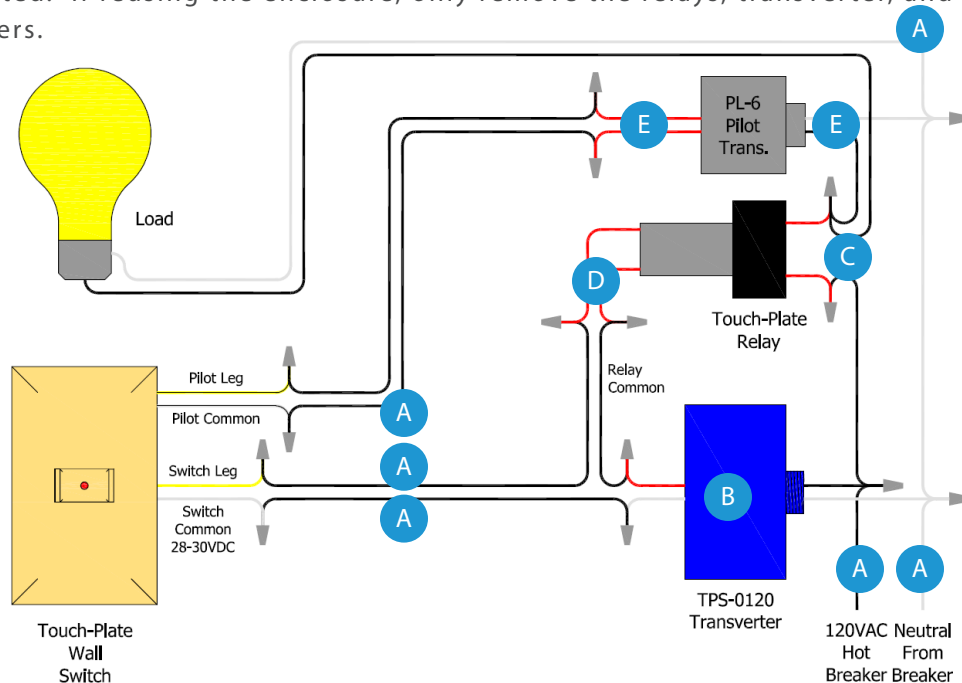

Line Voltage Wiring and Connections

Use the line voltage wiring connections diagram to setup your system. This diagram does not show all possible connections and configurations.

- A** Connect switch leg 1 from the lighting load to the terminal labeled DIM 1. Continue to do the same for switch leg's 2-6.
- B** Connect the neutral wires from each lighting load to the neutral bar.
- C** Bring a neutral feed from the neutral bar to each of the terminals labeled Neutral. Connect a neutral wire from the neutral bar to the KT3 block (Terminal Block).
- D** Connect the neutral wire from the breaker panel to the KT3 block (Terminal Block).
- E** Connect the hot wire from the breaker panel to the KT3 block (Terminal Block).
- F** Jump the hot feed from the KT3 block (Terminal Block) to each of the terminals labeled Hot.

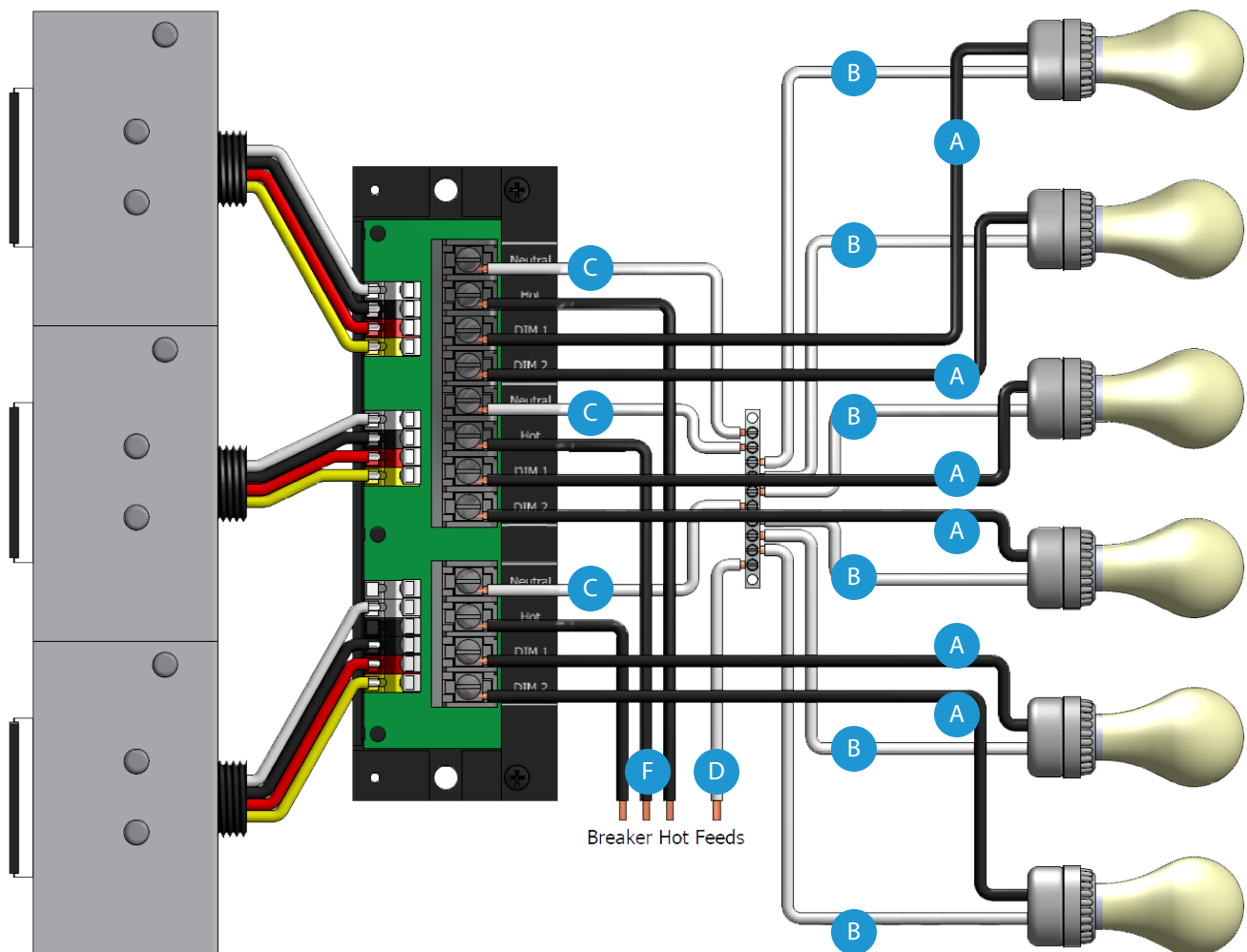

Contact Closure Switch Wiring and Connections (Dimmers 1-6)

Use the Contact Closure Switch wiring connections diagram to setup your system. This diagram does not show all possible connections and configurations.

The Contact Closure Switch Inputs are used when programming is not going to be used. The switches will be wired directly into the terminal of the corresponding dimmer.

For example, if button 1 is to control dimmer 1, the wire would be brought into the terminal labeled 'Dimmer 1'.

- A** Connect the button 1 wire to the desired terminal.
Continue to connect all button wires to the desired terminals.
Terminals available are Dimmer 1, Dimmer 2, Dimmer 3, Dimmer 4, Dimmer 5, and Dimmer 6.
- B** Connect the common wires to the terminal labeled 'SC' (Switch Common).

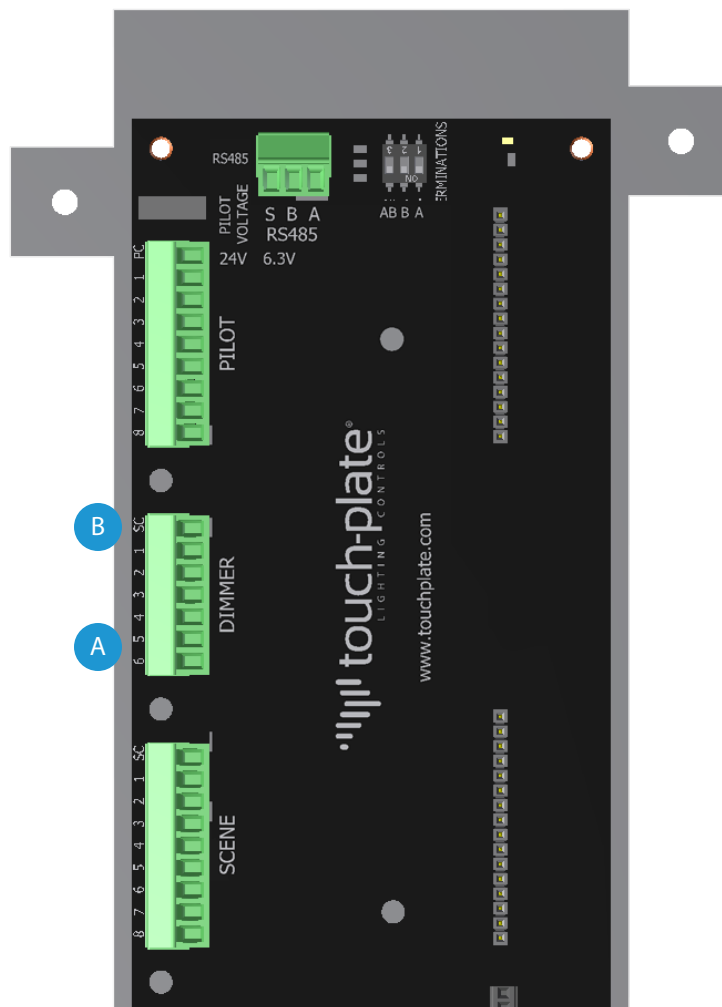

Contact Closure Switch Wiring and Connections (Scenes)

Use the Contact Closure Switch wiring connections diagram to setup your system. This diagram does not show all possible connections and configurations.

The purpose of the Scene Function is to define an action for a group of dimmers.

The Scene Inputs are used when programming is going to be used. The switches will be wired directly into the terminal of the corresponding Scene. Programming will need to take place before any of the buttons work properly.

For example, if button 1 is to control dimmers 1 - 3, the wire would be brought into the terminal labeled 'Scene 1'.

- A** Connect the button 1 wire to the desired scene terminal.
Continue to connect all button wires to the desired scene terminals.
Terminals available are Scene 1, Scene 2, Scene 3, Scene 4, Scene 5, Scene 6, Scene 7, and Scene 8.
- B** Connect the common wires to the terminal labeled 'SC' (Switch Common).

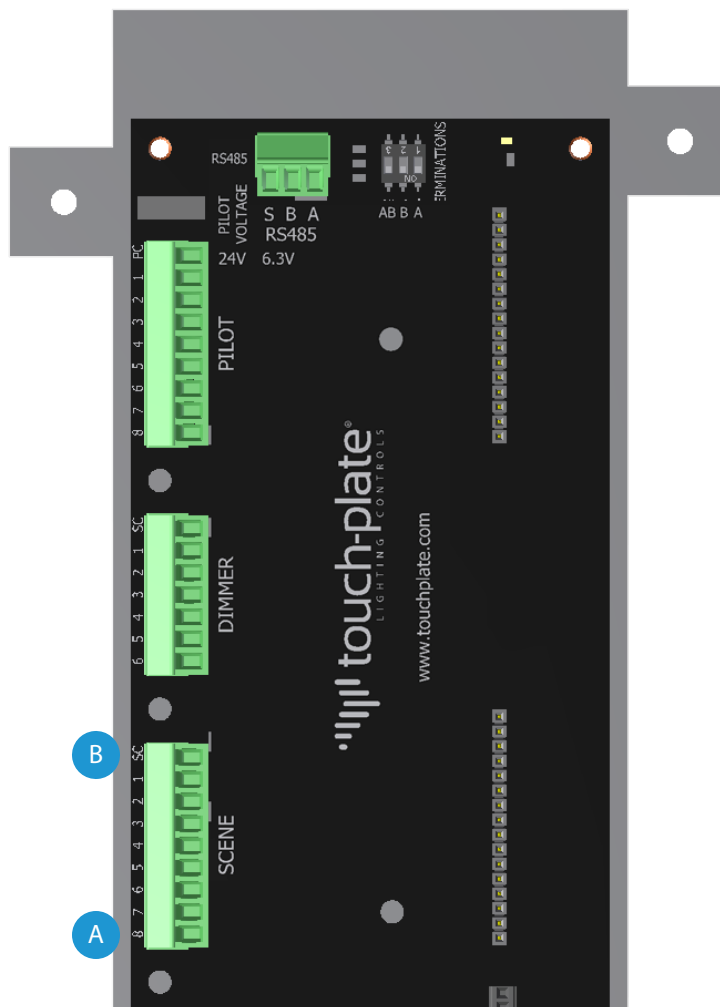

Contact Closure Switch Wiring and Connections (LED)

Use the Contact Closure Switch wiring connections diagram to setup your system. This diagram does not show all possible connections and configurations.

The LED outputs are used when LEDs are present on the Switches. These can be wired and used whether the Contact Closure Switch Inputs or Scene Inputs are used.

The LED outputs correspond to the LED location on the switch.

For example, when wiring LED #4 on the switch, bring the LED wire to the terminal labeled 'LED 4'.

- A** Connect the LED 1 wire to the desired terminal.
Continue to connect all LED wires to the desired terminals.
Terminals available are LED 1, LED 2, LED 3, LED 4, LED 5, LED 6, LED 7, and LED 8.
- B** Connect the common wires to the terminal labeled 'PC' (Pilot/LED Common).

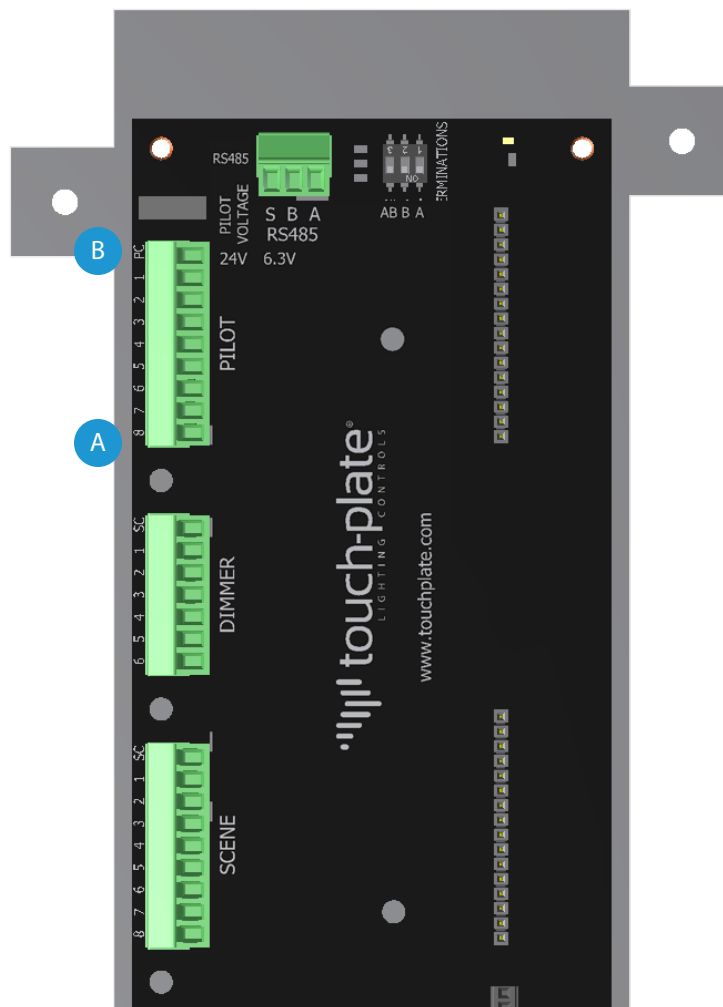

Programming Interface Explanations

These explanations will help to understand each section of the Interface and its definition.

Section	Item	Definition
Setup	Button	Press 1 time to turn on programming control
		Press and hold for 12 secs to clear the programming
Scene	1	Controls Scene 1
	2	Controls Scene 2
	3	Controls Scene 3
	4	Controls Scene 4
	5	Controls Scene 5
	6	Controls Scene 6
	7	Controls Scene 7
	8	Controls Scene 8
Output	1	Corresponds to Dimmer 1
	2	Corresponds to Dimmer 2
	3	Corresponds to Dimmer 3
	4	Corresponds to Dimmer 4
	5	Corresponds to Dimmer 5
	6	Corresponds to Dimmer 6
Action	None	No action will occur
	Up	The load dims up as the button is held
	Down	The load dims down as the button is held
	Cycle	Each button press cycles the load between ON and OFF.
	To	The button press dims the light to the preset level
	A15	If the lights are off, they will turn on. In 15 mins they will turn off. If the lights are on, they will stay on. After 15 mins, the lights will turn off.
	A30	If the lights are off, they will turn on. In 30 mins they will turn off. If the lights are on, they will stay on. After 30 mins, the lights will turn off.
A60	If the lights are off, they will turn on. In 1 hr they will turn off. If the lights are on, they will stay on. After 1 hr, the lights will turn off..	
Level	0	The load will dim to 0% out of 100%
	1	The load will dim to 1% out of 100%
	5	The load will dim to 5% out of 100%
	10	The load will dim to 10% out of 100%
	20	The load will dim to 20% out of 100%
	50	The load will dim to 50% out of 100%
	75	The load will dim to 75% out of 100%
	100	The load will dim to 100% out of 100%
Rate	Slow	The dimmer will dim to the level slower than the default setting
	Med	Default setting
	Fast	The dimmer will dim to the level faster than the default setting



Programming Scene Functions

Use the programming diagram to setup your system. Each load needs to have its Action determined before programming begins. Each system will have different programming characteristics and this document does not show all possible programming options.

- A Press the 'SETUP' button once to begin the programming.
- B Press the 'SCENE' button multiple times until the LED Is lit next to the Scene Number that is to be programmed.
- C Press the 'OUTPUT' button multiple times until the LED is lit next to the Dimmer Number that is to be programmed.
- D Press the 'ACTION' button multiple times until the LED Is lit next to the Action that is to be carried out by the dimmer.
- E Press the 'LEVEL' button multiple times until the LED Is lit next to the Level that the dimmer is to dim to.
- F Press the 'RATE' button multiple times until the LED is lit next to the Rate that indicates how fast the dimmer is to dim.
- G Press the 'SCENE' button to move to the next scene that is desired to be programmed.

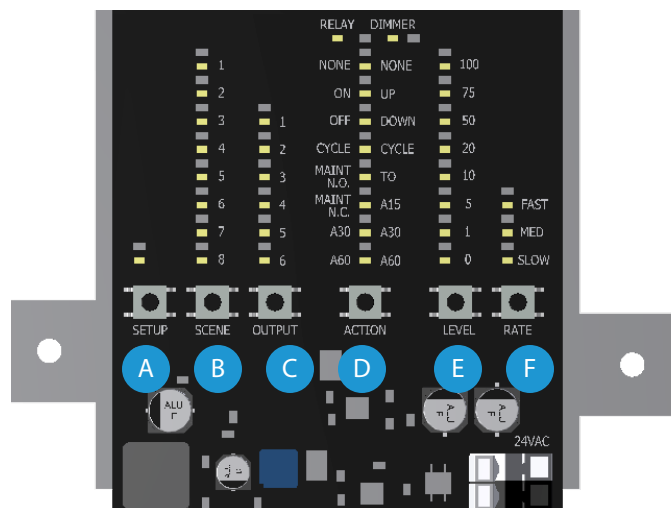

Programming LED Functions

Use the programming diagram to setup your system. These instructions are used to program an LED to respond to the Scene programming. Each system will have different programming characteristics and this document does not show all possible programming options.

- A** Press the 'SETUP' button twice to begin the programming.
- B** Press the 'SCENE' button multiple times until the LED Is lit next to the Scene Number that is to have a corresponding LED turned On.
- C** Press the 'SCENE' button to move to the next LED that is desired to be programmed.

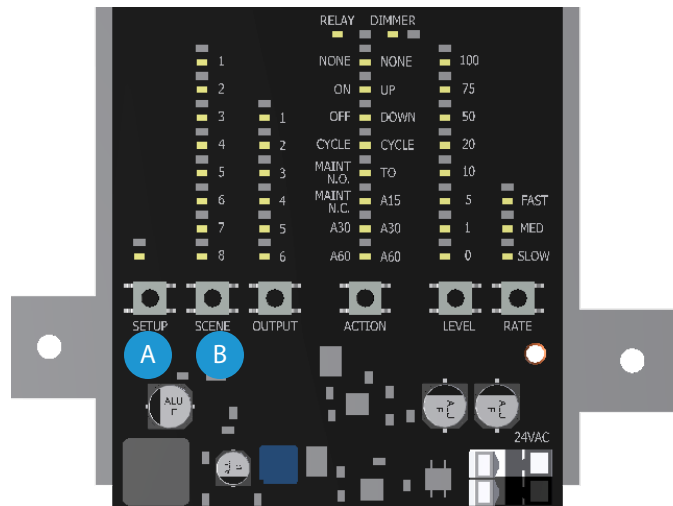

Address Dip Switches

The Address Dip Switches are used to set the DMX Address only if a Time-Keeper is present.

Normally, these Dip Switches come from the factory pre-programmed. If they do not, make sure you do not duplicate addresses, as each ZNZ-ZD must have its own unique address.

Note that each ZNZ-ZD utilizes 6 addresses. For example, if on one Time-Keeper network there were two (2) ZNZ-ZD's, the first would be set to Address 1 and the second would be set to Address 7.

Do not change values unless directed by Touch-Plate!!!

Address	1	2	3	4	5	6	7	8	9
1	ON	OFF	OFF	OFF	OFF	OFF	OFF	OFF	OFF
7	ON	ON	ON	OFF	OFF	OFF	OFF	OFF	OFF
13	ON	OFF	ON	ON	OFF	OFF	OFF	OFF	OFF
19	ON	ON	OFF	OFF	ON	OFF	OFF	OFF	OFF
25	ON	OFF	OFF	ON	ON	OFF	OFF	OFF	OFF
31	ON	ON	ON	ON	ON	OFF	OFF	OFF	OFF
37	ON	OFF	ON	OFF	OFF	ON	OFF	OFF	OFF
43	ON	ON	OFF	ON	OFF	ON	OFF	OFF	OFF
49	ON	OFF	OFF	OFF	ON	ON	OFF	OFF	OFF
55	ON	ON	ON	OFF	ON	ON	OFF	OFF	OFF
61	ON	OFF	ON	ON	ON	ON	OFF	OFF	OFF
67	ON	ON	OFF	OFF	OFF	OFF	ON	OFF	OFF
Valid Addresses are through Address 72									

Valid addresses are between 1 to 72. Addresses are set using the nine Address Dip Switches, which each have a value noted in the chart below.

Address Dip Switch	1	2	3	4	5	6	7	8	9
Value	1	2	4	8	16	32	64	128	256

The values of all switches in the ON position are added together and the total is equal to the address. See the examples below:

DMX Address 1: Turn on switch 1 only, and leave all other Address switches off.

DMX Address 13: Turn on switches 1, 3 and 4. The values of those switches is $1 + 4 + 8 = 13$.



Option Dip Switches

The Other Dip Switches are used to set different functions.

Option	ON/OFF	Definition
1	ON	LED follows the individual load
1	OFF	LED follows the Scene
2	ON	LED follows the individual load
2	OFF	LED follows the Scene
3	ON	LED follows the individual load
3	OFF	LED follows the Scene
4	ON	LED follows the individual load
4	OFF	LED follows the Scene
5	ON	LED follows the individual load
5	OFF	LED follows the Scene
6	ON	LED follows the individual load
6	OFF	LED follows the Scene
7	ON	Tests each load and the LED status output. The test starts at dimmer 1 and dims the load from 0% - 100% - 0%. While it is dimming, the LED status will be on while the load dims. Once dimmer 1 is complete, the test will move sequentially through the remaining dimmers.
7	OFF	Test mode is off

Termination Dip Switches

The Termination Dip Switches are used to set the Terminations.

Terminations	Definition
A	Pull Up
B	Pull Down
AB	Termination

LED Intensity Dip Switches

The Pilot Intensity Dip Switches are used to set the LED Intensity. This option is only used when the factory has been contacted.

Intensity	Definition
1	ON = Low Intensity
2	ON = Medium Intensity
1 & 2	1 ON & 2 ON = High Intensity



Troubleshooting Guide

If no response occurs when the system is powered up, use the following steps to identify the problem.

1. Remove the Diecut from the ZNZ-ZD.
2. Look for the LED indicator to be blinking.
 - a. For the indicator to be blinking, power has to be correctly brought to the system.
 - b. If the LED indicator is not blinking, confirm power connections and then contact the factory for assistance.
 - c. If the LED indicator is blinking, move on to the next step.
3. Verify that the line voltage has been fed to all the necessary relays.
4. Verify that each light fixture is connected to the 'Switched Leg'.
5. Utilize Dip Switch #7. See page 14 for instructions.
6. Verify that 120 VAC has been connected to the transformer
7. Take a short piece of thin wire (both ends need to be stripped) and hold one end to the conductive metal of the 'Switch Common'.
8. Take the other end of the short wire and tap it to the conductive metal of each of the Dimmer terminals, on the ZNZ-ZD, one at a time.
 - a. Each touch should energize the dimmer and change its state. The lights in the respective rooms should go ON and OFF when the terminal is touched.
9. If the lights do not respond, use a meter on the line voltage dimmer outputs to see if the voltage switches from 0 to 120 VAC.
10. If these steps do not solve the problem, please contact the factory for assistance.



Frequently Asked Questions

1. What are Scenes?
 - a. Scenes allow for a single button to control multiple dimmers.
 - b. For example: In most bathrooms there are lights above the sink and above the shower. If both lights are desired to be turned on at the same time with the push of a single button, a Scene makes this possible.
2. What are the 'Option' Functions?
 - a. Option Functions are to be used when a Time-Keeper is connected to the ZNZ-ZD.
3. What is the 'DMX Address'?
 - a. The DMX Address is a number in a line of specific addresses.
 - b. This has to be done because everything has a unique address and has to be programmed to do so.
4. What are the wattages on the dimmer modules?
 - a. The Standard dimmer module is 300W per channel.
 - b. There is an option available that is 600W per channel.
5. What are the 'Terminations'?
 - a. These are DMX line terminations. This is only used if a DMX controller is connected to the ZNZ-ZD
6. How do you save the programming?
 - a. The programming is saved once the Scene, Dimmer, Action, Level, or Rate is entered and the button press is released.





Touch-Plate ZoneZ Dimmer Manual
Revision: 2.0a

