

Industrial Wiring Diagram for Single Pole Single Throw (SPST) Systems

Use the following to wire an Industrial Switch. SPST systems are Touchplate and similar two-wire systems.

Each system will have different components and this document does not show all possible connections.

Button Layout

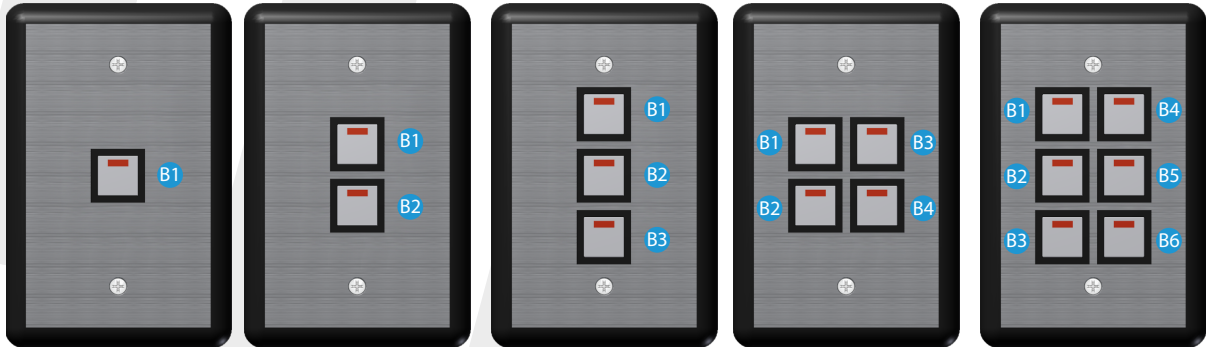

Switch and LED Wiring

- Switch wires are yellow; switch common wires are white.
- LED wires are yellow with a black stripe; LED common wires are white with a black stripe.
- Recommended wire size is 16-18 AWG

Powering the Station

- **LED Voltage Range:** 10 - 24VDC; use of a separate power supply will require the use of separate commons.
- **Draw on LED Resistor:** Max of 4mA per LED.
- **Shared Common:** When using a single common to power both the switches and LEDs, a wire is needed to connect both common wires together.
- **Separate Commons:** When using separate commons to power the switches and LEDs, the common wires will be wired separately.

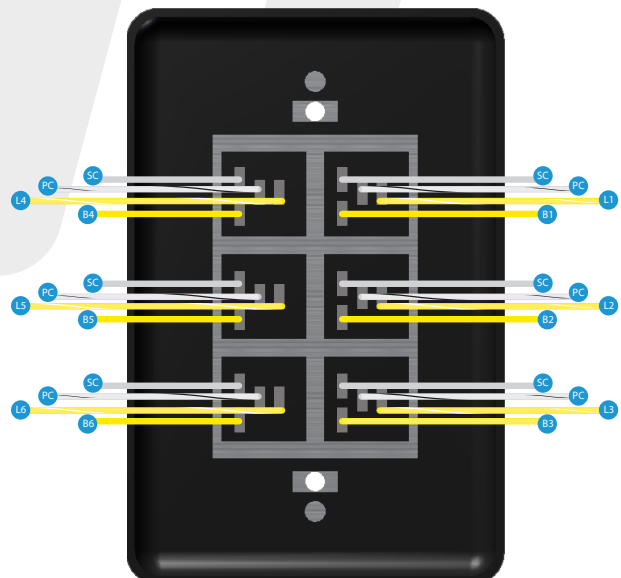

Industrial Wiring Diagram for Single Pull Double Throw (SPDT) Systems

Use this wiring diagram to wire your control station. Each system will have different components and this document does not show all possible connections.

Button Layout



Switch and LED Wiring

- Switch wires are yellow; switch common wires are white.
- LED wires are yellow with a black stripe; LED common wires are white with a black stripe.
- Recommended wire size is 16-18 AWG

Powering the Station

- **LED Voltage Range:** 10 - 24VDC; use of a separate power supply will require the use of separate commons.
- **Draw on LED Resistor:** Max of 4mA per LED.
- **Shared Common:** When using a single common to power both the switches and LEDs, a wire is needed to connect both common wires together.
- **Separate Commons:** When using separate commons to power the switches and LEDs, the common wires will be wired separately.

