



Soluxe Optima Quick Start Guide

Table Of Contents

Preparation	2
Warranty.	2
Soluxe Optima Overview	3
Soluxe Optima RS485 Wiring	4
Soluxe Optima to Relay Board Wiring	5
Soluxe Optima Line Voltage Wiring	6
Soluxe Optima RS-485 Termination Dip Switches.	7
Setting the Soluxe Optima Address.....	8
Troubleshooting Guide	9
Frequently Asked Questions.....	10

Preparation

Unpack the Soluxe Optima and inspect the contents for damaged or missing products. If any problems arise, please contact Touch-Plate at 260.426.1565 for assistance.

Precautions

The Soluxe Optima hardware is designed to be in environments that have a temperature range of 0-60°C (non-condensing atmosphere). Installing in an environment outside of these parameters will shorten the life span of the hardware.

Touch-Plate recommends the use of solid or stranded 18 to 22 AWG wire for low voltage wiring of contact closure products, 18 AWG wire for all 24v power connections, and 16 AWG wire for Smart Switch Stations.

All 120VAC wiring must use wire as specified by National Electric Code for load size and wire length.

Compatible Hardware

The Soluxe Optima is a control board that can be a part of a networked, intelligent system.

- Panel Products (Relay Board)
- Master Control Products
 - Time-Keeper Series
 - Nexus Series

Warranty

Touch-Plate warrants this product against defects in materials or workmanship, under normal use, for a period of ONE (1) year from date of shipment. If a defect arises and a valid claim is received within the Warranty Period, Touch-Plate will repair or replace the product at no charge.

This warranty does not apply to:

- a. Damage to unit(s) caused by accident, acts of God, inappropriate installation, faulty installation, or any negligent use;
- b. Unit(s) which have been subject to being taken apart or otherwise modified;
- c. Unit not used in accordance with instructions;
- d. The finish on any portion of the product, such as surface and/or weathering, as this is considered normal wear and tear;
- e. Non-Touch-Plate hardware installed by the user;
- f. Damage caused by Non-Touch-Plate products;
- g. Damage caused by operating the product outside the permitted or intended uses described by Touch-Plate;
- h. -or- Specific plans or Specific application requirements, unless the plans and specifications have been forwarded to Touch-Plate and Touch-Plate has approved and accepted the plans in writing.

EXCEPT AS PROVIDED IN THIS WARRANTY, TOUCH-PLATE IS NOT RESPONSIBLE FOR DIRECT, SPECIAL, INCIDENTAL, OR CONSEQUENTIAL DAMAGES RESULTING FROM ANY BREACH OF WARRANTY OR CONDITION, INCLUDING BUT NOT LIMITED TO, INSTALLATION OR REPLACEMENT LABOR COSTS.



Soluxe Optima Overview

The Soluxe Optima is a part of a networked, intelligent system.

- The green blinking light on the Soluxe Optima is the “heartbeat”. This indicates that power has properly been brought to the system.

Board Items	Options	Board Position	Page #
Low Voltage Connections	RS485 Connection	A	4
	Relay Board Connection	B	5
	Manual Overrides	C	10
Line Voltage Connections	Transformer Feed	D	7
	Switch Leg Feeds (SW1 to SW6)	E	7
	Neutral Bar	F	7
	Ground Lug/Ground Bar	G	7
Dip Switches	RS485 Terminations	H	8
	Address	I	9

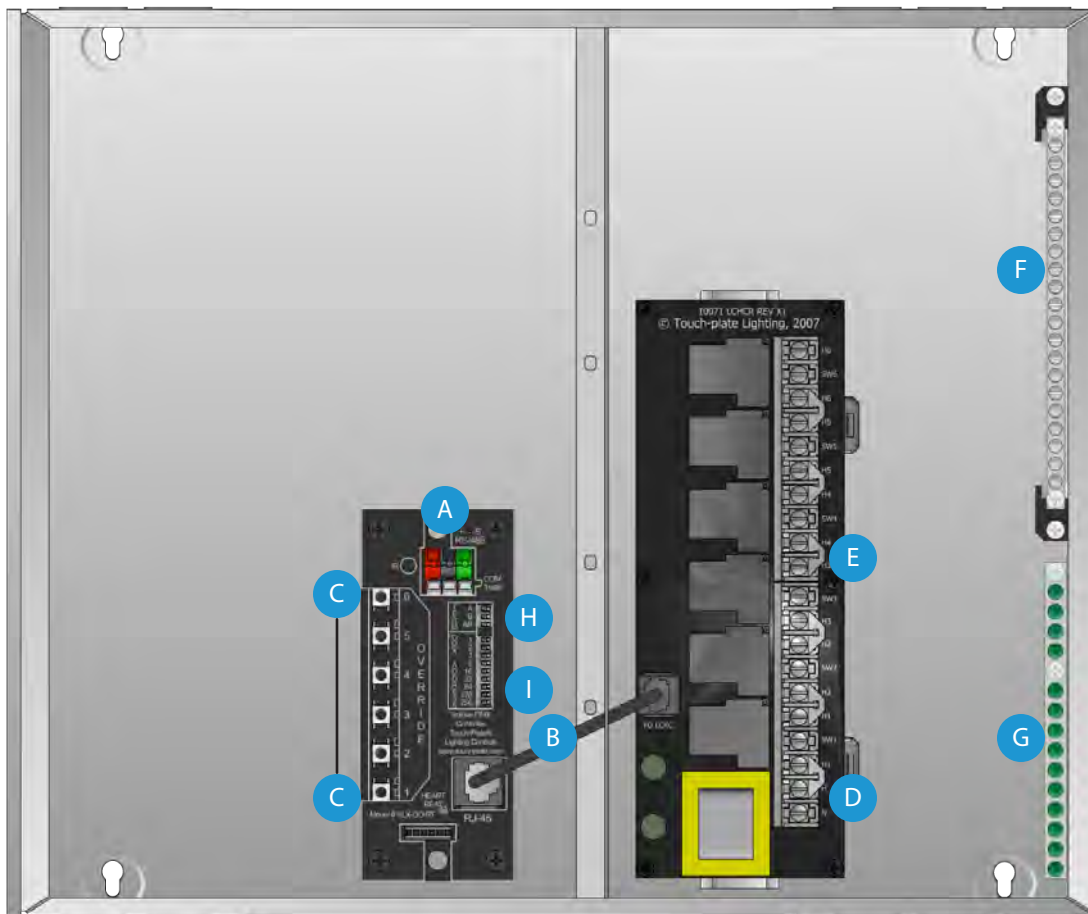

Soluxe Optima RS485 Wiring

To correctly wire the RS485 connection to the Soluxe Optima, use the wiring diagram below.

- **Shield or Ground for RS485 connection must be isolated from the ground on the power supply. Using the same ground will create a direct short across the diode bridge and damage the unit!**

Wire must be Liberty 18/2C SHLD or an equivalent wire.

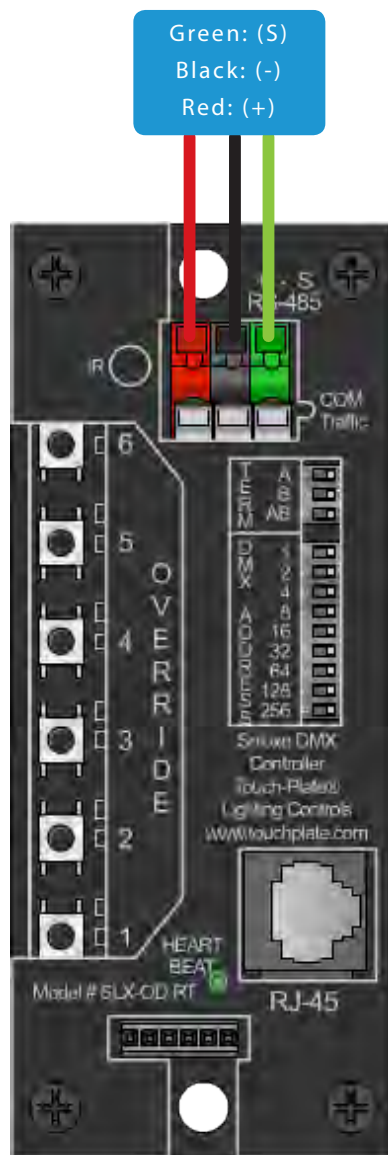

Soluxe Optima to Relay Board Wiring

To correctly wire the Soluxe Optima to the Relay Board, use the wiring diagram below.

- An RJ-45 cable is provided from the factory. If a longer cable is desired or needed, Touch-Plate recommends the use of a standard Cat5 patch cable.

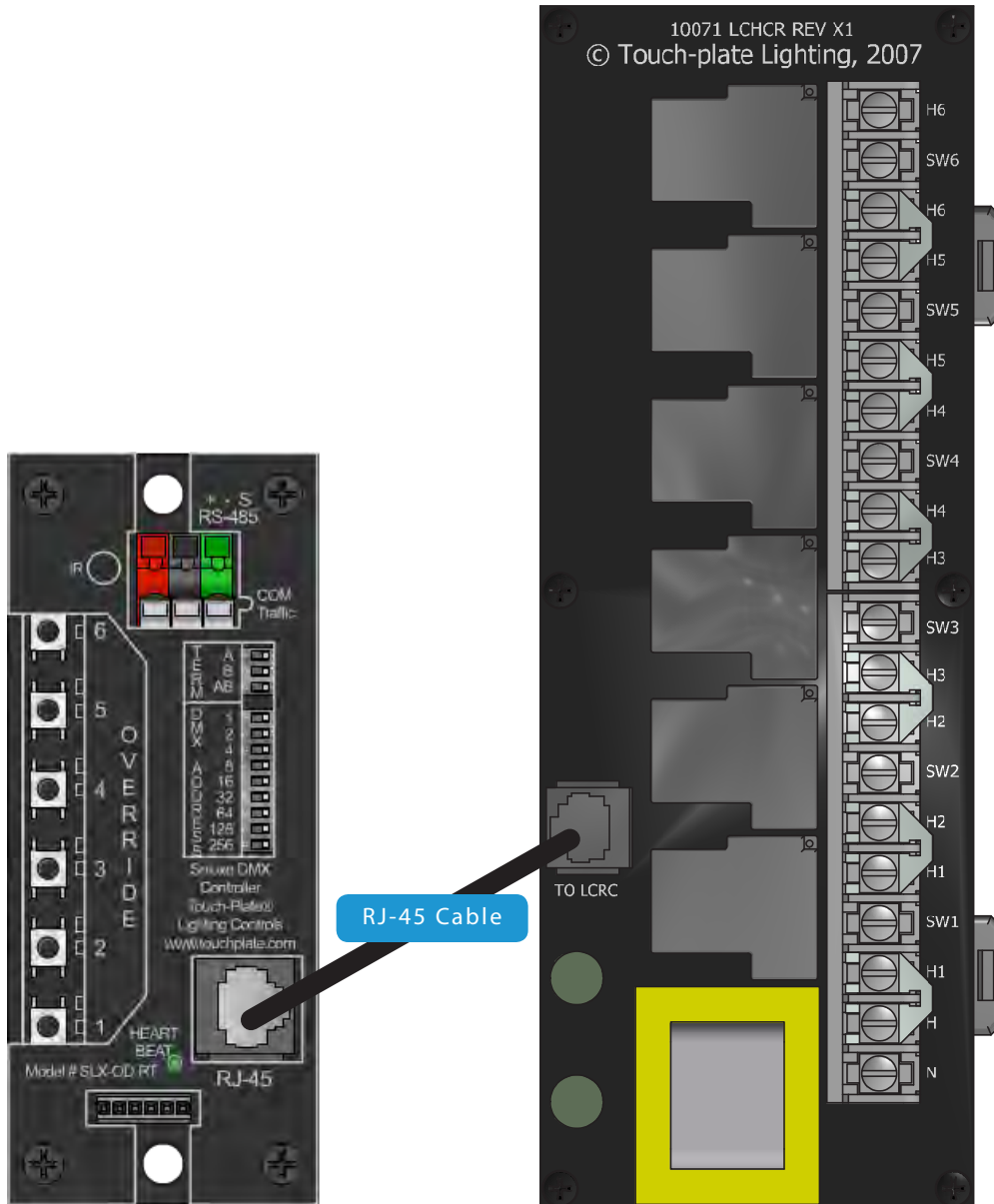

Soluxe Optima Line Voltage Wiring

To correctly wire line voltage connections to the Relay Board, use the wiring diagram below.

- Terminals labeled H-H6 are hot terminals. These come from the factory with jumpers, which jump the hot terminals together. Jumpers can be removed if each load has its own hot feed.
- Jumpers have to be removed if a voltage other than that specified on the transformer is needed.
- Relay wattage supported is:
 - 20 amp electronic relays: 1920 watts per relay, as long as each relay has its own feed from the breaker panel.
 - 25 amp mechanically latching relay: 2400 watts per relay, as long as each relay has its own feed from the breaker panel.

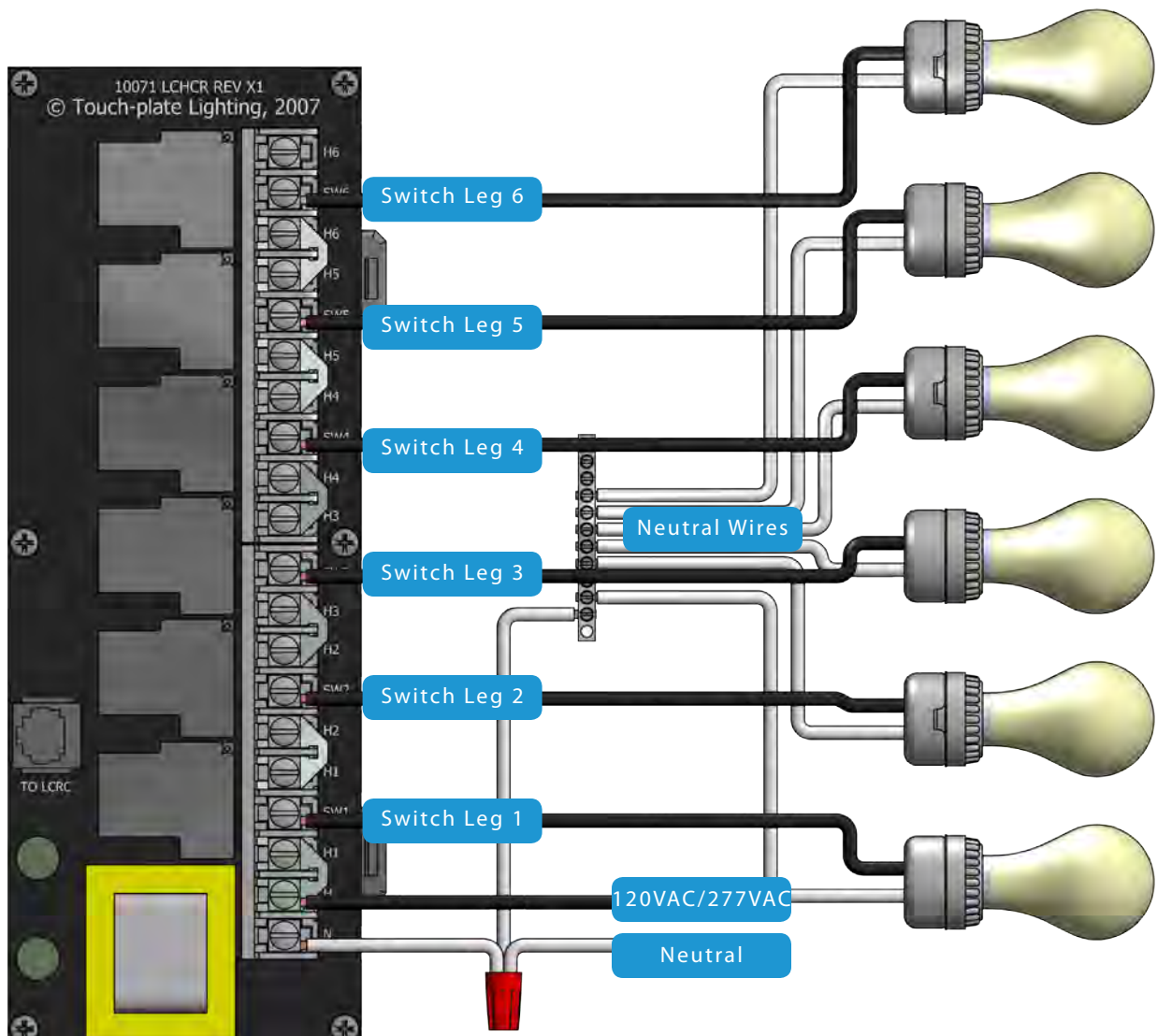

Soluxe Optima RS-485 Termination Dip Switches

The RS485 Termination Dip Switches are used to set RS485 terminations.

Option	1	2	3
RS485 Termination (Non-Inverting Input Pull Up; 510 Ohms)	ON	OFF	OFF
RS485 Termination (Inverting Input Pull Up; 510 Ohms)	OFF	ON	OFF
RS485 Termination (Line to Line Termination; 120 Ohms)	OFF	OFF	ON



Setting the Soluxe Optima Address

The Address Dip Switches are used to set the Address.

Normally, these Dip Switches come from the factory pre-programmed to Address #1.

Use the setting diagram to change the Address if needed. Note that for the address changes to take effect, a power cycle needs to occur.

Address	1	2	3	4	5	6	7	8	9
1	ON	OFF	OFF	OFF	OFF	OFF	OFF	OFF	OFF
2	OFF	ON	OFF	OFF	OFF	OFF	OFF	OFF	OFF
3	ON	ON	OFF	OFF	OFF	OFF	OFF	OFF	OFF
4	OFF	OFF	ON	OFF	OFF	OFF	OFF	OFF	OFF
5	ON	OFF	ON	OFF	OFF	OFF	OFF	OFF	OFF
6	OFF	ON	ON	OFF	OFF	OFF	OFF	OFF	OFF
7	ON	ON	ON	OFF	OFF	OFF	OFF	OFF	OFF
8	OFF	OFF	OFF	ON	OFF	OFF	OFF	OFF	OFF
9	ON	OFF	OFF	ON	OFF	OFF	OFF	OFF	OFF
10	OFF	ON	OFF	ON	OFF	OFF	OFF	OFF	OFF
11	ON	ON	OFF	ON	OFF	OFF	OFF	OFF	OFF
12	OFF	OFF	ON	ON	OFF	OFF	OFF	OFF	OFF
13	ON	OFF	ON	ON	OFF	OFF	OFF	OFF	OFF
14	OFF	ON	ON	ON	OFF	OFF	OFF	OFF	OFF
15	ON	ON	ON	ON	OFF	OFF	OFF	OFF	OFF
16	OFF	OFF	OFF	OFF	ON	OFF	OFF	OFF	OFF
17	ON	OFF	OFF	OFF	ON	OFF	OFF	OFF	OFF
18	OFF	ON	OFF	OFF	ON	OFF	OFF	OFF	OFF
19	ON	ON	OFF	OFF	ON	OFF	OFF	OFF	OFF
20	OFF	OFF	ON	OFF	ON	OFF	OFF	OFF	OFF
Valid Addresses are 1-256									

Valid addresses are from 1 to 72. Addresses are set using the nine Address Dip Switches, which each have a value noted in the chart below.

Address Dip Switch	1	2	3	4	5	6	7	8	9
Value	1	2	4	8	16	32	64	128	256

The values of all switches in the ON position are added together and the total is equal to the address. See the examples below:

Address 1: Turn on switch 1 only, and leave all other Address switches off.

Address 13: Turn on switches 1, 3 and 4. The value of those switches are $1 + 4 + 8 = 13$.



Troubleshooting Guide

If no response occurs when the system is powered up, use the following steps to identify the problem.

1. Look for the LED indicator to be blinking on it.
 - a. For the indicator to be blinking, power has to be correctly brought to the system. If the LED indicator is blinking, move on to step 2.
 - b. If the LED indicator is not blinking, confirm power connections and then contact the factory for assistance.
2. Verify that the line voltage has been fed to all the necessary dimmers.
3. Verify that each light fixture is connected to the switched leg.
4. Verify that 120 VAC has been connected to the transformer on the relay board.
5. If these steps do not solve the problem, please contact the factory for assistance.



Frequently Asked Questions

1. Can I update just one section of my Touch-Plate system?
 - a. In most applications just one section of the Touch-Plate system cannot be updated.
 - b. There are some applications where one section of the Touch-Plate system can be updated. This is only possible when there are no shared commons and each panel location has its own transverter.
2. What are the manual overrides?
 - a. The manual overrides are used to manually cycle the relays on and off.





Touch-Plate Soluxe Optima Quick Start Guide
Revision: 2.0a

