



Aura Exterior Wiring Manual
(5-Wire and BACnet)



Table Of Contents

Preparation	2
Warranty.	2
Aura Exterior Product Overview	3
Aura Exterior Power Wiring.....	4
Aura Exterior RS485 Wiring	5
Troubleshooting Guide	6

Preparation

Unpack the Aura Exterior sensor and inspect the contents for damaged or missing products. If any problems arise, please contact Touch-Plate at 260.426.1565 for assistance.

Precautions

The Aura Exterior hardware is designed to be in environments that have a temperature range of 0-60°C (non-condensing atmosphere). Installing in an environment outside of these parameters will shorten the life span of the hardware.

Touch-Plate recommends the use of 18 to 22 AWG wire for low voltage wiring of contact closure products, 18 AWG wire for all 24v power connections, and 16 AWG wire for Smart Switch Stations.

All 120VAC wiring must use wire as specified by National Electric Code for load size and wire length.

Compatible Hardware

The Aura is a smart sensor that can be a part of a networked, intelligent system.

Warranty

Touch-Plate warrants this product against defects in materials or workmanship, under normal use, for a period of ONE (1) year from date of shipment. If a defect arises and a valid claim is received within the Warranty Period, Touch-Plate will repair or replace the product at no charge.

This warranty does not apply to:

- a. Damage to unit(s) caused by accident, acts of God, inappropriate installation, faulty installation, or any negligent use;
- b. Unit(s) which have been subject to being taken apart or otherwise modified;
- c. Unit not used in accordance with instructions;
- d. The finish on any portion of the product, such as surface and/or weathering, as this is considered normal wear and tear;
- e. Non-Touch-Plate hardware installed by the user;
- f. Damage caused by Non-Touch-Plate products;
- g. Damage caused by operating the product outside the permitted or intended uses described by Touch-Plate;
- h. -or- Specific plans or Specific application requirements, unless the plans and specifications have been forwarded to Touch-Plate and Touch-Plate has approved and accepted the plans in writing.

EXCEPT AS PROVIDED IN THIS WARRANTY, TOUCH-PLATE IS NOT RESPONSIBLE FOR DIRECT, SPECIAL, INCIDENTAL, OR CONSEQUENTIAL DAMAGES RESULTING FROM ANY BREACH OF WARRANTY OR CONDITION, INCLUDING BUT NOT LIMITED TO, INSTALLATION OR REPLACEMENT LABOR COSTS.



Aura Exterior Product Overview

The Aura Exterior is a powerful and versatile sensor with the capability to control both relays and dimmers as a part of a networked, intelligent system.

The Aura Exterior sensor has a 4 level light sensor built-in.

Board Items	Options	Position	Page #
Low Voltage Connections	18-24VDC Power Connection (Yellow/Yellow)	A	4
	RS485 Connection (Green/Black/Red)	B	5
	Ribbon Cable (Not featured in the drawing)	-	5

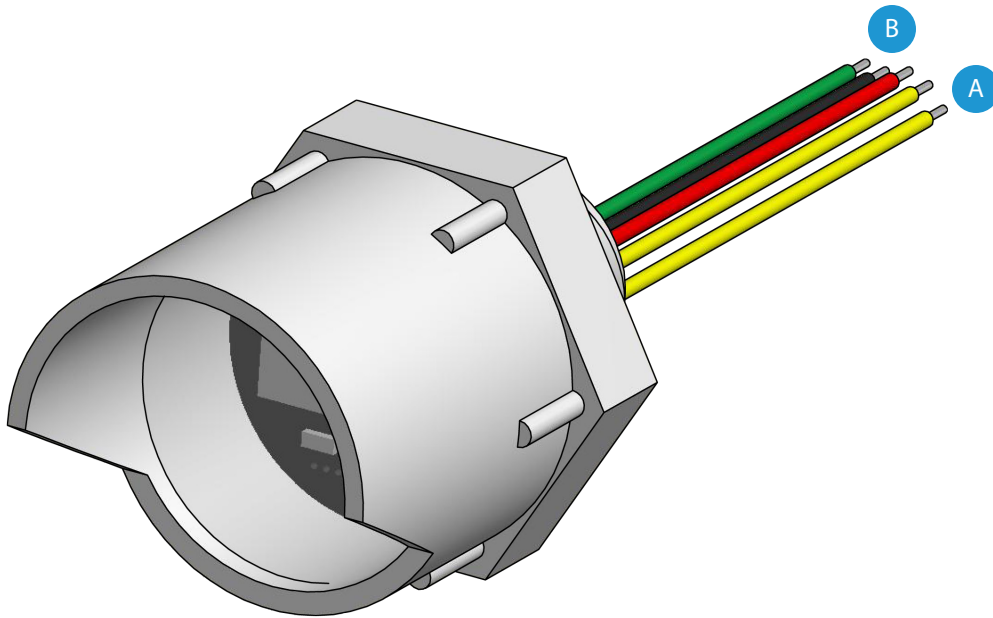

Aura Exterior Power Wiring

To correctly bring power to the Aura Exterior Sensor, use the wiring diagram below.

Only attempt to power one unaddressed sensor at a time per room. If there are multiple sensors, but only one per room, then they can all be powered at once.

Power must be a Class 2, Isolated Transformer, with a rating of 12 - 24 VAC/VDC.

Wire must be Axlink 22/01PSH + 18/2C or an equivalent wire.

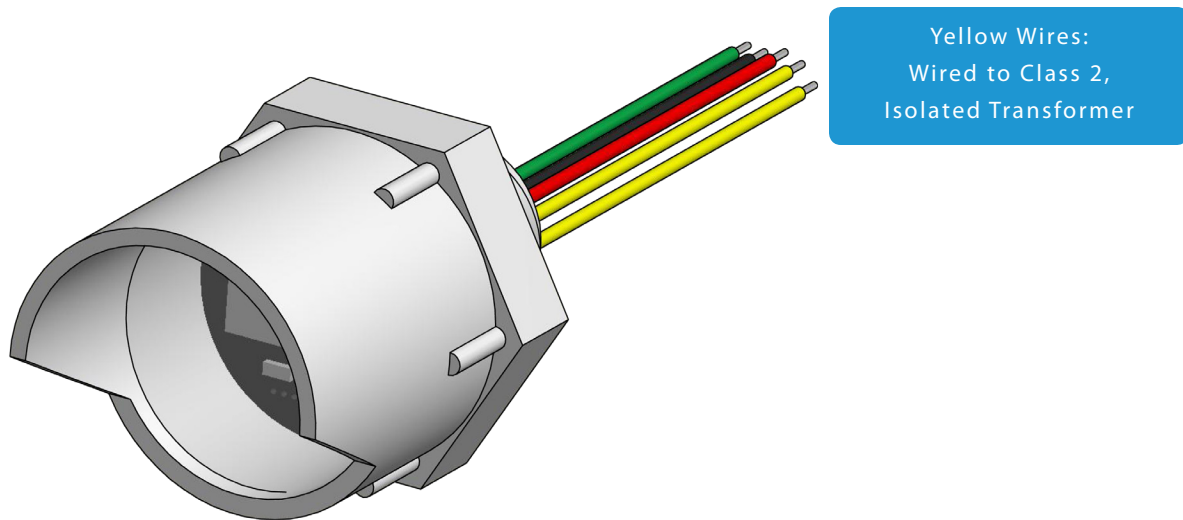

Aura Exterior RS485 Wiring

To correctly wire the RS485 connection to the Aura Exterior Sensor, use the wiring diagram below.

- **Shield or Ground for RS485 connection must be isolated from the ground on the power supply. Using the same ground will create a direct short across the diode bridge and damage the unit.**
- **The ribbon cable that is on the Aura Exterior Sensor is for factory purposes only.**

Wire must be Axlink 22/01PSH + 18/2C or an equivalent wire.

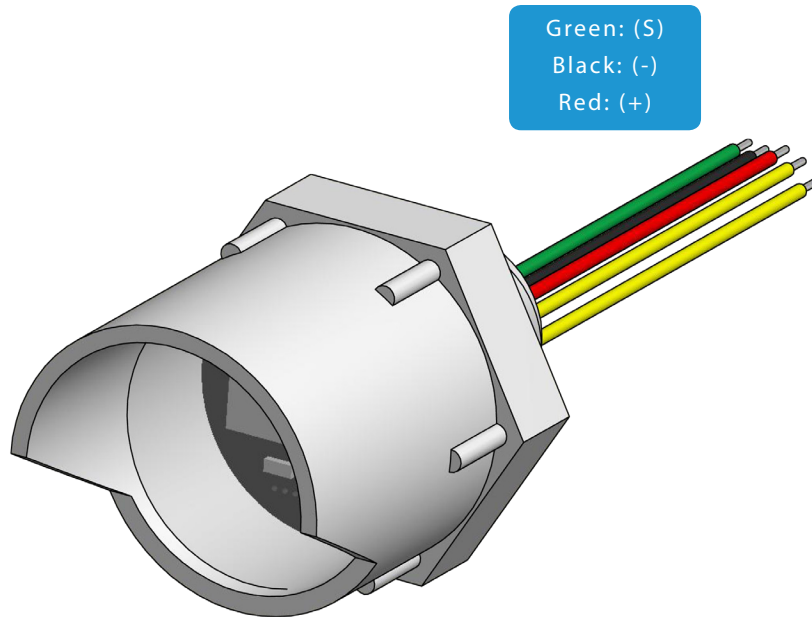

Troubleshooting Guide

1. If the LEDs on the sensors stations do not flash.
 - a. Verify that the wiring is correct.
 - b. Verify that all devices are connected to power.





Touch-Plate Aura Exterior Wiring Manual
Revision: 2.0a

